

APPLICATIONS

Feed pumps for exhaust gas boilers on diesel ships

GENERAL CHARACTERISTICS

Item	Model	SVQ50(L)	SVQ50A
Type		Vertical	Horizontal
Rotation		CW(CCW) when viewed from the driver	
Suction bore (mm)		50	
Discharge bore (mm)		50	
Stuffing box seal		Gland packing or Mechanical seal	
MAX.output (kW)		18.5	
weight:FC(FCD) (kg)		110	
Water filled in casing (kg)		6	



PERFORMANCE CHART

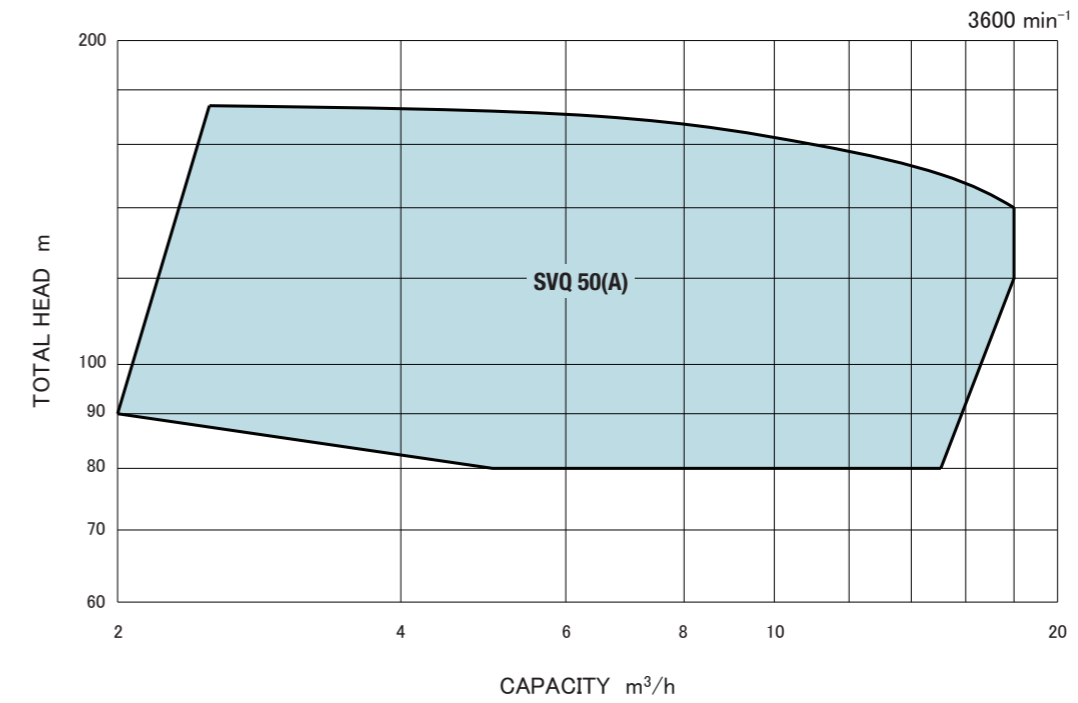

SVQ 50(L)~50A

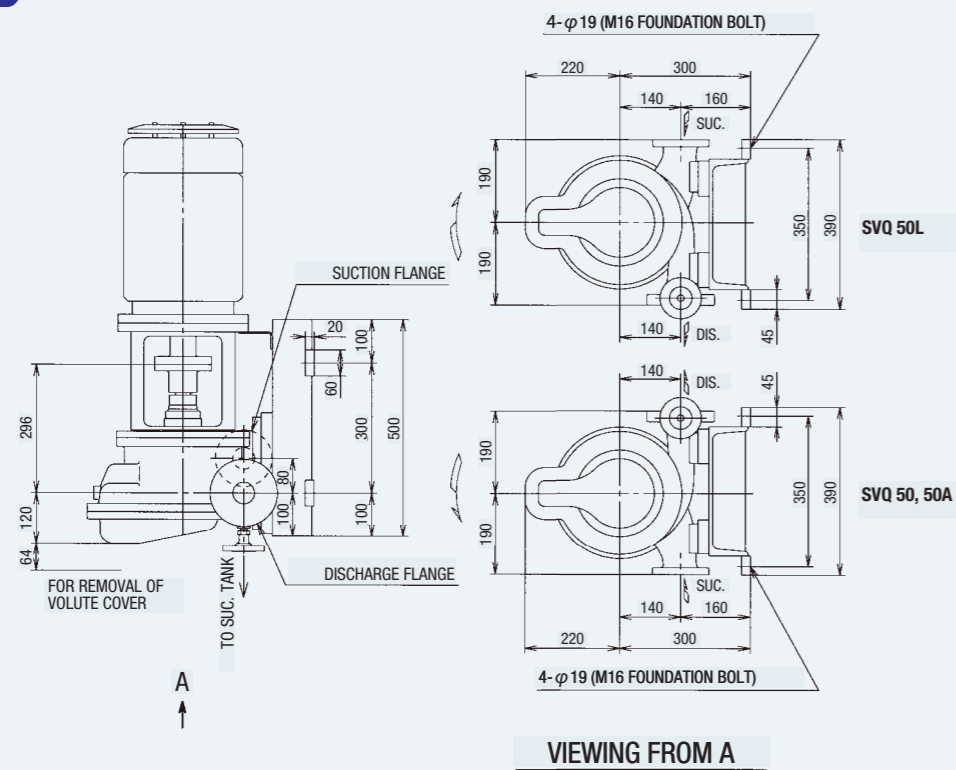

Note :
When attaching two pumps to the cascade tank wall, symmetrical pumps can be used.