

### APPLICATIONS

- Fresh water pumps
- Sanitary pumps
- Refrigerator cooling water pumps
- Other use

### GENERAL CHARACTERISTICS

Item	Model	HJ 40-2
Rotation		Clockwise when viewed from the driver
Suction bore	(mm)	40
Discharge bore	(mm)	40
Stuffing box seal		Gland packing or Mechanical seal
Max.output	(kW)	7.5
weight:CAC	(kg)	41
weight:FC	(kg)	38
Water filled in casing	(kg)	0.8



### PERFORMANCE CHART

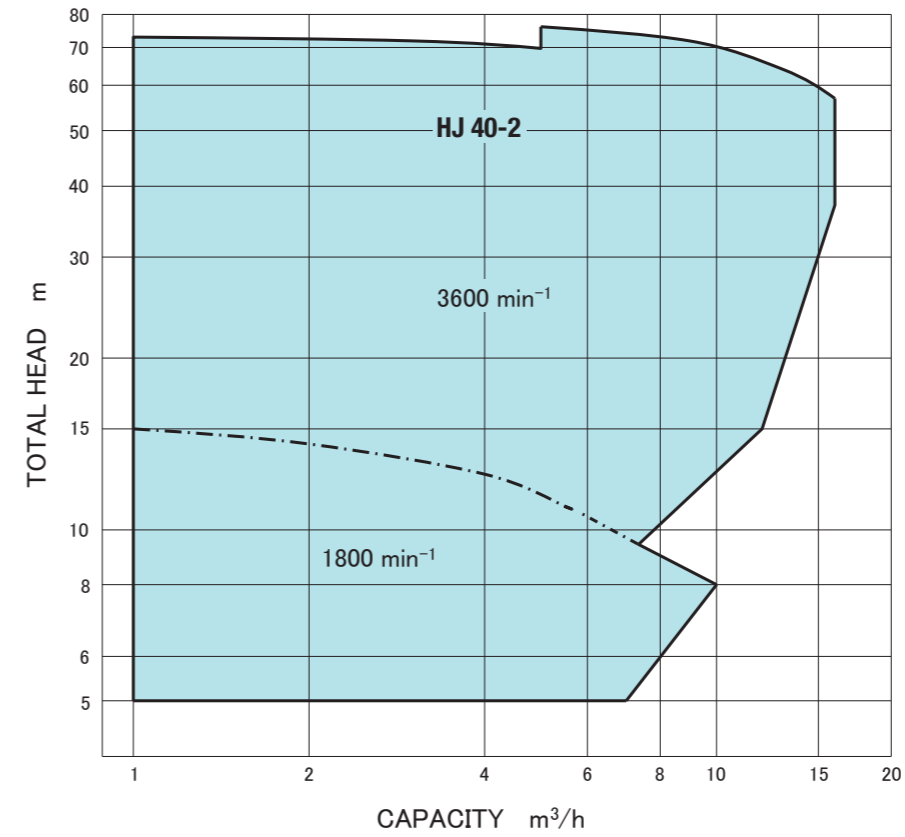

### HJ 40-2

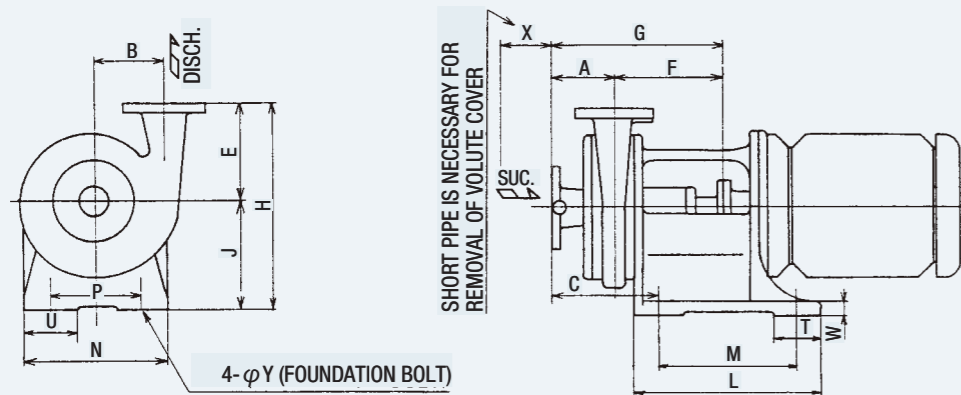

Dimensions:mm

Model	A	B	C	E	F	G	H	J	L	M	N	P	T	U	W	X	Y	Mecha. seal
HJ 40-2	90	100	150	150	132	222	320	170	300	260	270	230	50	50	13	100	19	25