

Vertical single-suction axial-flow deep-well CENTRIFUGAL PUMPS



APPLICATIONS

- Water intake pumps
- General cooling pumps
- Other general use

SPECIFICATIONS

- Total head 15 to 45m
- Temperatures Below 100°C

GENERAL CHARACTERISTICS

Item	Model	SB 150	SB 200	SB 250	SB 300	SB 350
Rotation		Clockwise when viewed from the driver				
Discharge bore (mm)		150	200	250	300	350
Ball bearings		6309	6311	6311	6311	6314
Service life (hr)		Above 60000				
Amount of grease filled (g)		20	30	30	30	50
Tank bottom to bell mouth (mm)		80	100	120	140	170
Required min. water level (mm)		350	350	430	500	570
Stuffing box seal		Gland packing or mechanical seal				
Weight (except motor) (kg)		590 (40)	890 (50)	1240 (63)	1750 (108)	2700 (163)

Ball bearing size varies with length of shaft.
Weight refers to L = 2 m, and increases as shown in bracket with 1 m increase in L.



DESIGN & STANDARD MATERIALS

PART NO.	NAME OF PART	MATERIAL		REQ.NO. FOR 1 PUMP
		NAME	JIS	
1	VOLUTE CASING	CAST IRON	FC200	1
2	VOLUTE COVER	"	"	1
4	PUMP BED	"	"	1
5	MOTOR BED	STEEL	SS400	1
7	BEARING HOUSING	CAST IRON	FC200	1
9	BEARING COVER	"	"	1
16	IMPELLER	PHOSPHOR BRONZE	CAC502A	1
18	IMPELLER SHAFT	Cr-Mo STEEL	SCM435	1
22	SLEEVE	STAINLESS STEEL	SUS403	1
23	SLEEVE	"	"	1
27	IMPELLER NUT	"	SUS304	1
34	BALL BEARING	SPECIAL STEEL		1
38	MOUTH RING	BRONZE	CAC403	2
41	LINE BEARING	CARBON		1
46	LANTERN BUSH	BRONZE	CAC406	1
47	GLAND	"	"	1
49, 50	COUPLING	DUCTILE CAST IRON	FCD400	2
54	GLAND PACKING	CARBONIZED FIBER		1 SET
140	DISCHARGE PIPE	STEEL	SS400	1
318	COUPLING BOLT & NUT	"	SS400	1 SET
319	COUPLING RING	RUBBER		1 SET

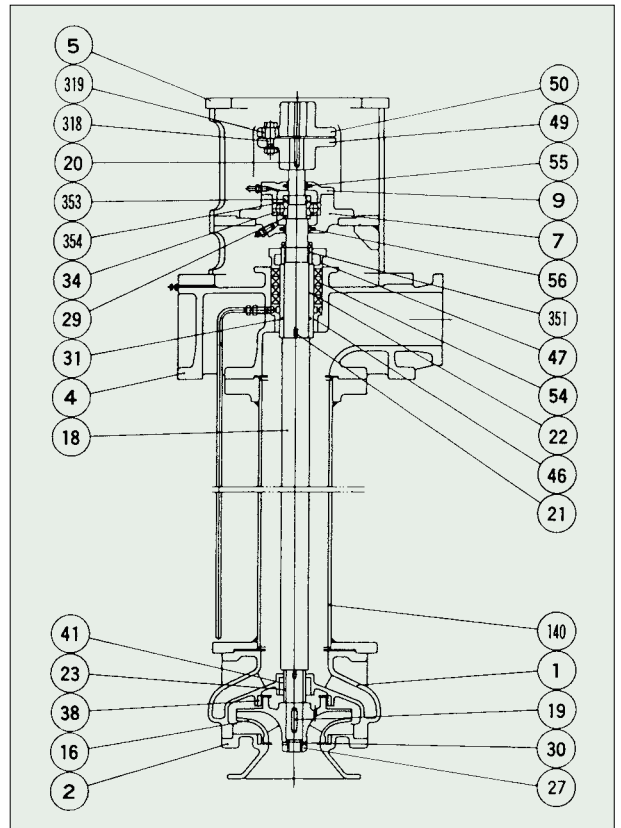

50Hz

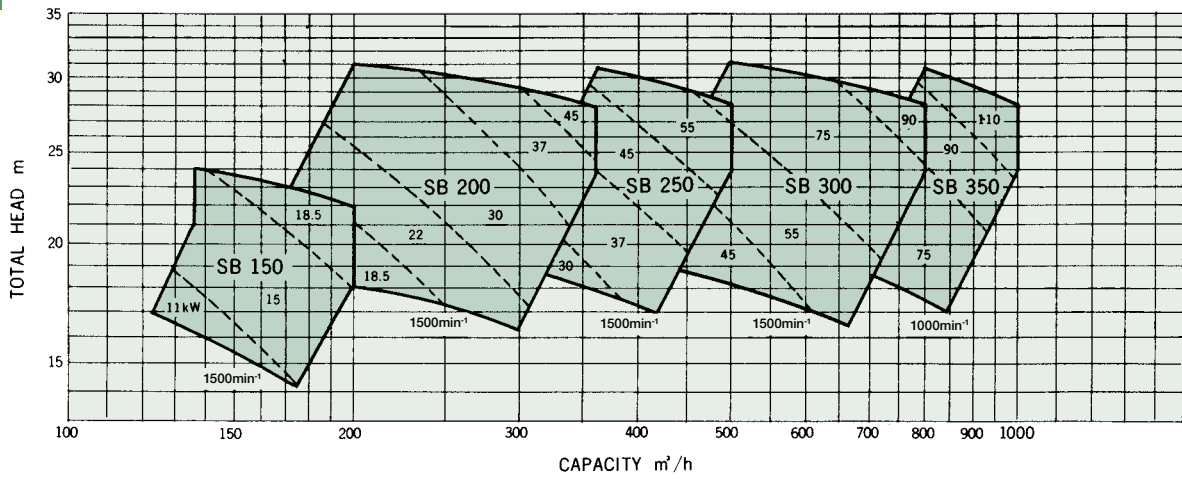

60Hz

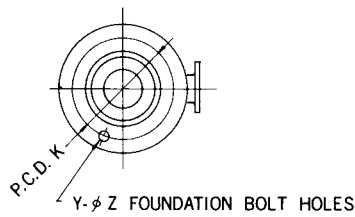
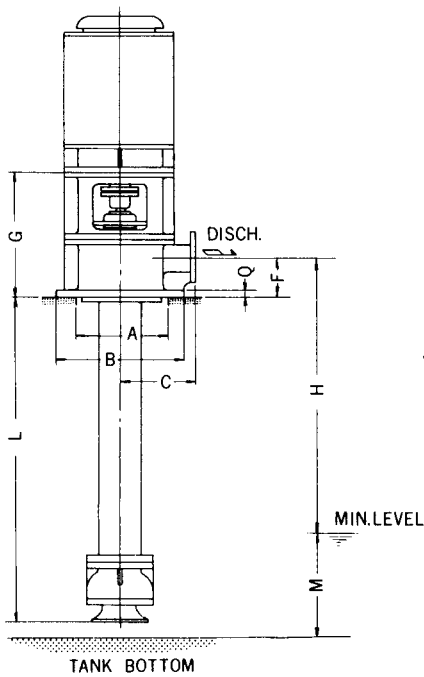
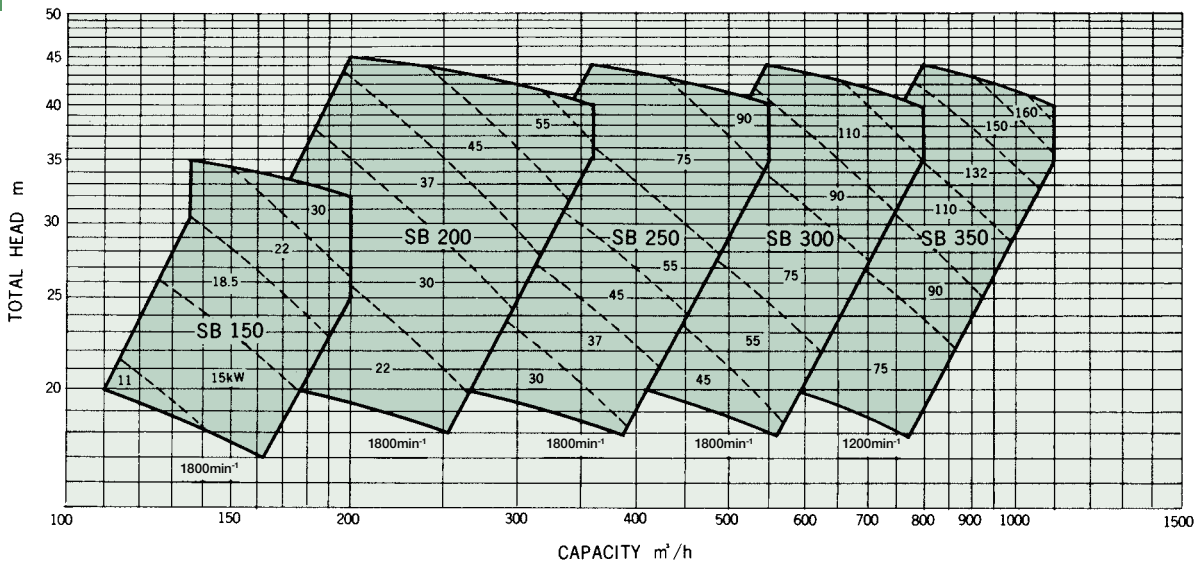

Model	A	B	C	F	G	K	M	Q	Y	Z
SB 150	480	640	385	250	800	590	350	32	8	25
SB 200	585	750	420	320	950	700	350	38	8	25
SB 250	650	850	430	400	1050	790	430	42	12	25
SB 300	730	940	540	475	1175	880	500	42	12	25
SB 350	950	1130	620	550	1355	1070	570	42	12	27

SHINKO IND.LTD.