

Vertical two-stage single/double-suction CONDENSATE PUMPS

SHINKO EVZ

APPLICATIONS

Condensate pumps
Drain transfer pumps
Other general use

SPECIFICATIONS

Total head 18 to 140m
Temperatures Below 100°C

GENERAL CHARACTERISTICS

Item	Model	EVZ 50	EVZ 70	EVZ 100	EVZ 130	EVZ 130-2	EVZ 150
Rotation		Clockwise when viewed from the driver					
Suction bore (mm)		100	125	200	250	250	300
Discharge bore (mm)		50	65	100	125	125	150
Ball bearings		6306	7309DF	7311DF	7311DF	7311DF	7311DF
Service life (hr)		Above 60000					
Amount of grease filled (g)		8	35	55	55	55	55
Stuffing box seal		Gland packing or mechanical seal					
Weight (except motor) (kg)		185	470	530	590	640	760

1st stage impeller: Single suction for EVZ 50 · 70 · 100
Double suction for EVZ 130 · 130-2 · 150

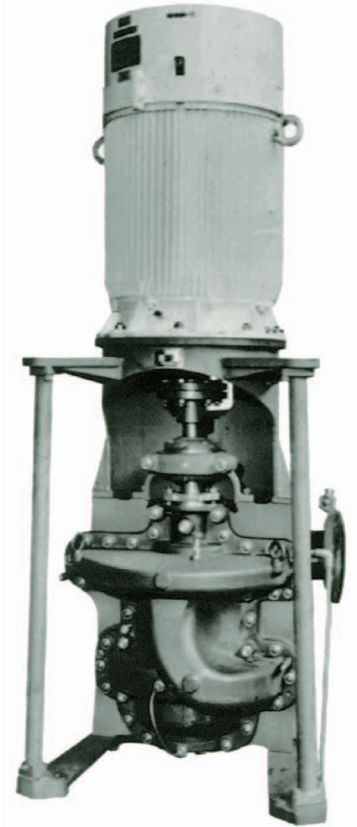

DESIGN & STANDARD MATERIALS

PART NO.	NAME OF PART	MATERIAL		REQ.NO. FOR 1 PUMP
		NAME	JIS	
1	VOLUTE CASING	CAST IRON	FC200	1
2	VOLUTE COVER	"	"	1
4	PUMP BED	"	"	1
5	MOTOR BED	STEEL	SS400	1
7	BEARING HOUSING	CAST IRON	FC200	1 SET
16, 17	IMPELLER	PHOSPHOR BRONZE	CAC502A	2
18	IMPELLER SHAFT	STAINLESS STEEL	SUS403	1
22	SLEEVE	"	"	1
24	SLEEVE	"	"	1
34	BALL BEARING	SPECIAL STEEL		1 SET
38	MOUTH RING	BRONZE	CAC403	4
39	CASING RING	"	CAC406	1
41	LINE BEARING	CARBON		1
44	NECK BUSH	BRONZE	CAC406	1
45	SEALING RING	SYNTHETIC RESIN		1
47	GLAND	BRONZE	CAC406	1
49, 50	COUPLING	DUCTILE CAST IRON	FCD400	2
54	GLAND PACKING	CARBONIZED FIBER		1 SET
318	COUPLING BOLT & NUT	STEEL	SS400	1 SET
319	COUPLING RING	RUBBER		1 SET

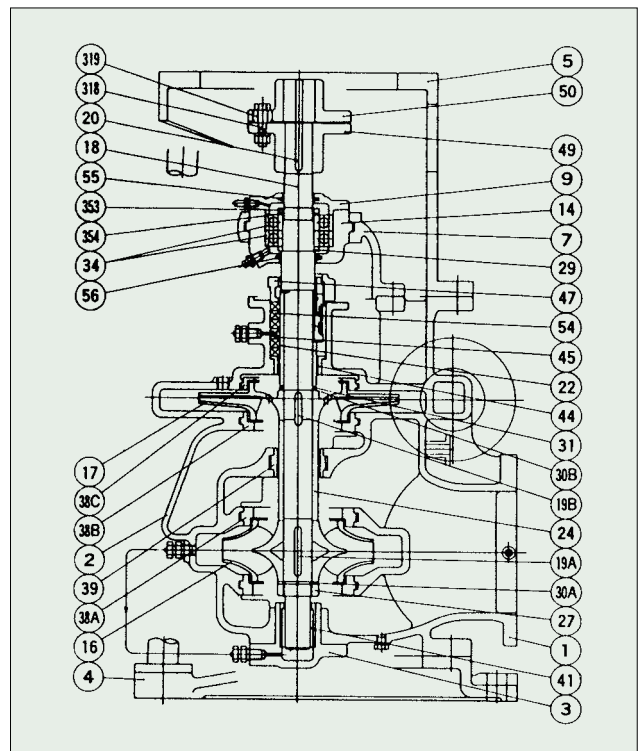

50Hz

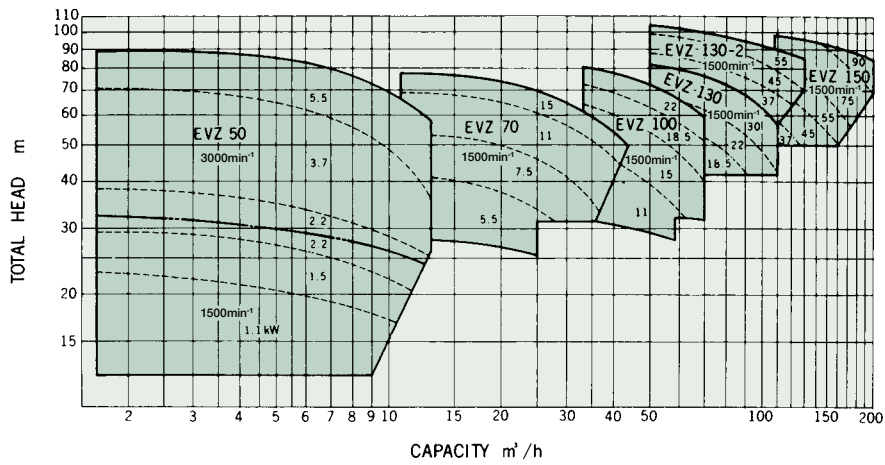

60Hz

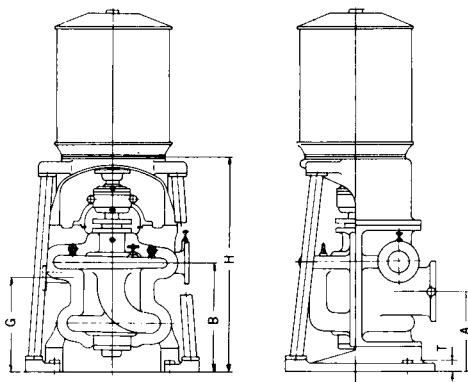
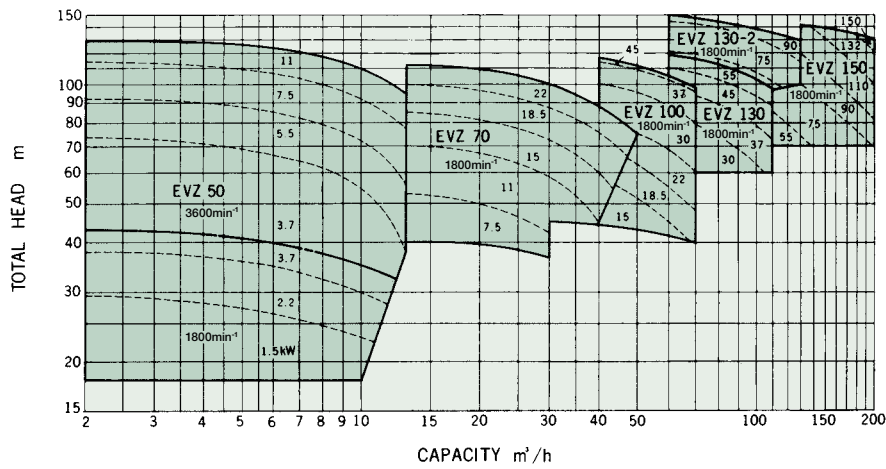

(EVZ 70, 100, 130, 130-2)

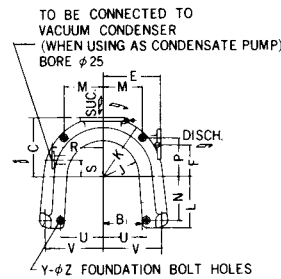

(EVZ 50)

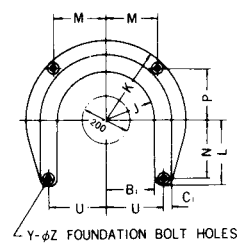

(EVZ 150)

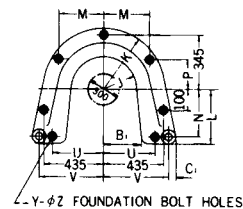

mm

Model	A	B	C	E	F	G	H	J	K	L	M	N	P	R	S	T	U	V	Y	Z	B ₁	C ₁
EVZ 50	210	310	260	260	120	270	712	155	270	225	170	200	170	150	150	50	180	-	4	23	159	21
EVZ 70	330	460	350	330	210	395	973	225	365	300	240	245	240	320	105	50	305	380	4	27	279	40
EVZ 100	350	490	350	330	210	440	1122	225	365	300	240	245	240	320	100	50	305	380	4	27	279	40
EVZ 130	300	590	410	350	270	530	1222	225	365	300	240	245	240	345	120	50	305	380	4	27	279	40
EVZ 130-2	300	590	440	380	320	530	1222	225	365	300	240	245	240	345	120	50	305	380	4	27	279	40
EVZ 150	325	670	460	380	345	585	1166	225	375	300	290	240	190	400	140	50	370	470	7	33	340	60

SHINKO IND.LTD.